

THE INTERRELATION OF ENVIRONMENTAL ASPECTS AND THE LOCATION OF LNG IMPORT TERMINALS

GASTECH 2009 • 25-28 May 2009 • Abu Dhabi Exhibition Centre • UAE

Presented by

Hans – J. Grossmann , GOC Engineering GmbH

Co-authored by

Eberhard Lange, Vice President, LNG Logistics, E.ON Ruhrgas AG

- Introduction
- Key Factors for Site Selection
- Environmental Requirements
- Case Study
- Consequences for *LNG* Terminals
- What to do?
- Summary



- LNG Terminals are huge investments and large infrastructure projects
- In particular the site selection of an LNG Import Facility often conflicts with site – related environmental and permit issues
- Local Environmental Impact Assessments requires that the effects of specific projects on the environment can be identified, described and assessed comprehensively

- According to this Act, all potential effects and interactions have to be considered on a number of protected assets such as human beings, including human health, fauna, flora and biological diversity, soil, water, air, climate, landscape and cultural heritage

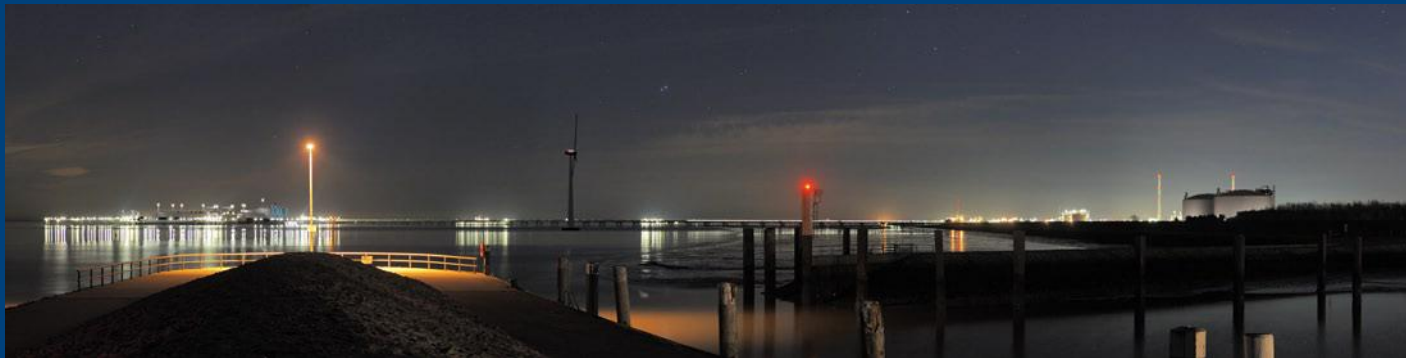

▶ What are the key factors for a Site Selection ?

- Introduction
- Key Factors for Site Selection
- Environmental Requirements
- Case Study
- Consequences for *LNG* Terminals
- What to do?
- Summary



Key Factors

- Marine infrastructure
- Water depths
- Existing infrastructures
- Geology/Soil conditions
- Weather conditions
- Neighborhood



Key Factors

- Competition
- Market access



Source : Public Domain

Key Factors

- Safety/Hazards/Risk
- Security

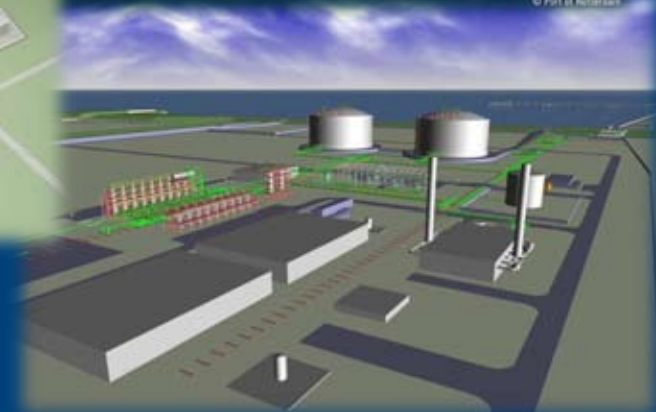
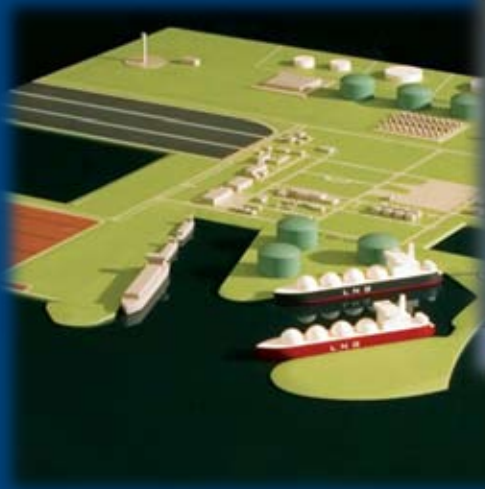

▶ Environmental Requirements

Source: Public Domain

Key Factors

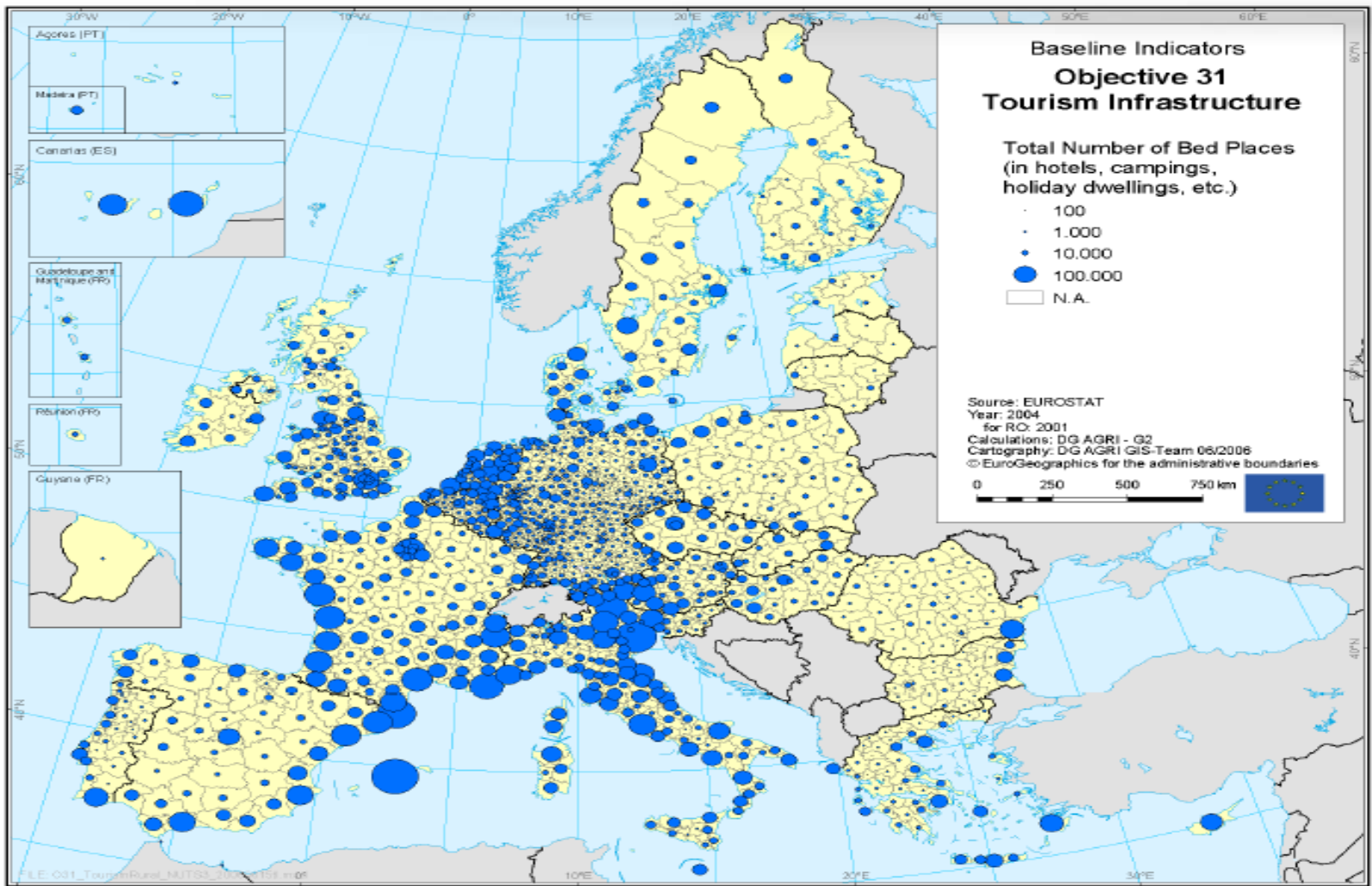

- Introduction
- Key Factors for Site Selection
- Environmental Requirements
- Case Study
- Consequences for *LNG* Terminals
- What to do?
- Summary



Environmental Impact Assessments (EIA)

- CO₂ emissions
- Emissions of greenhouse gases
- Noise emissions
- Flaring
- Water pollutions
- Visual impact



▶ Let`s have a more specific look to NATURA 2000

NATURA 2000

- NATURA 2000 based on two EU legislations:
 - EU's Birds Directive (79/409/EEC)
 - Habitats Directive (92/43/EEC)
- NATURA 2000 is the EU-wide network of nature conservation areas setup to ensure the survival of Europe's most valuable species and habitats

Source: European Commission

NATURA 2000

- By the end of 2008, the network will comprise more than **25 000** sites, covering around **20%** of the total land area of the EU – around 800 000 km² - plus 100 000 km² of marine environment.
- NATURA 2000 is still under development across the EU-27 Member States

Source: European Commission

NATURA 2000 – Impact Assessment - Required Steps

- Identification of affected sites
- Identification of the site conservation objectives
- Determination of the potentially affected conservation objectives
- Identification of other relevant plans and projects
- Delineation of the area for a detailed investigation
- Identification of need for investigation

▶ What does it mean **FOR YOUR PROJECT ?**

- Introduction
- Key Factors for Site Selection
- Environmental Requirements
- Case Study
- Consequences for *LNG* Terminals
- What to do?
- Summary



Case Study

- North Sea
- German Bight
- Tideland
- Tourism area





Case Study



Case Study



Case Study



Case Study



Source : DFTG

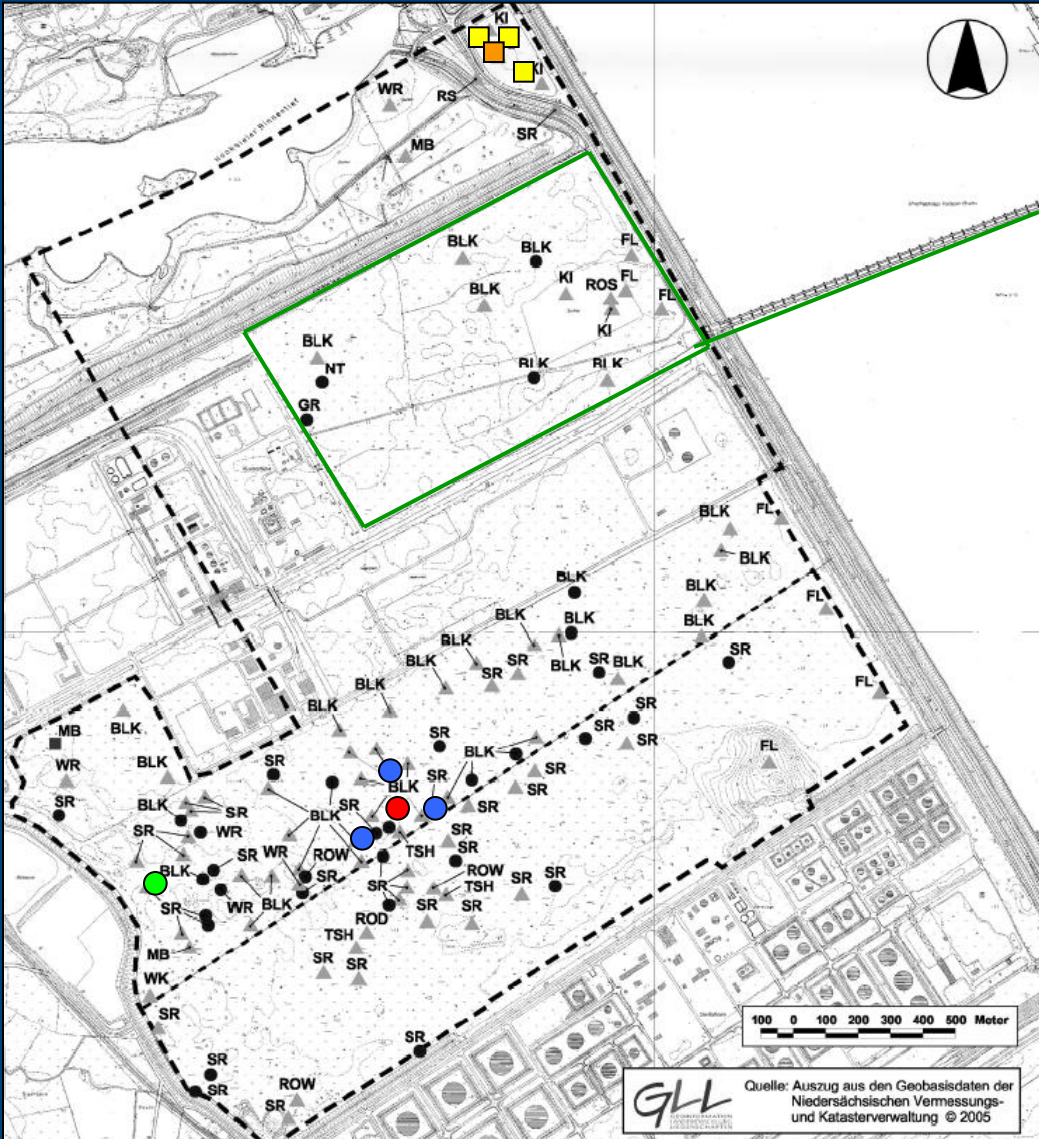

- Bittern
- Spotted crane
- Corn crake
- Peewit
- Redshank

▶ How will it affect the project?

Case Study

Example Bittern (*Botaurus stellaris*)

- one discovered male
- counted as a pair

▶ SILENCE PLEASE!

Sound level limits:

- 52 dB(A) during day !
- 47 dB(A) at night !



Piling Works

(worse scenario)

-  > 60 dB(A)
-  > 52 dB(A)
-  > 47 dB(A)

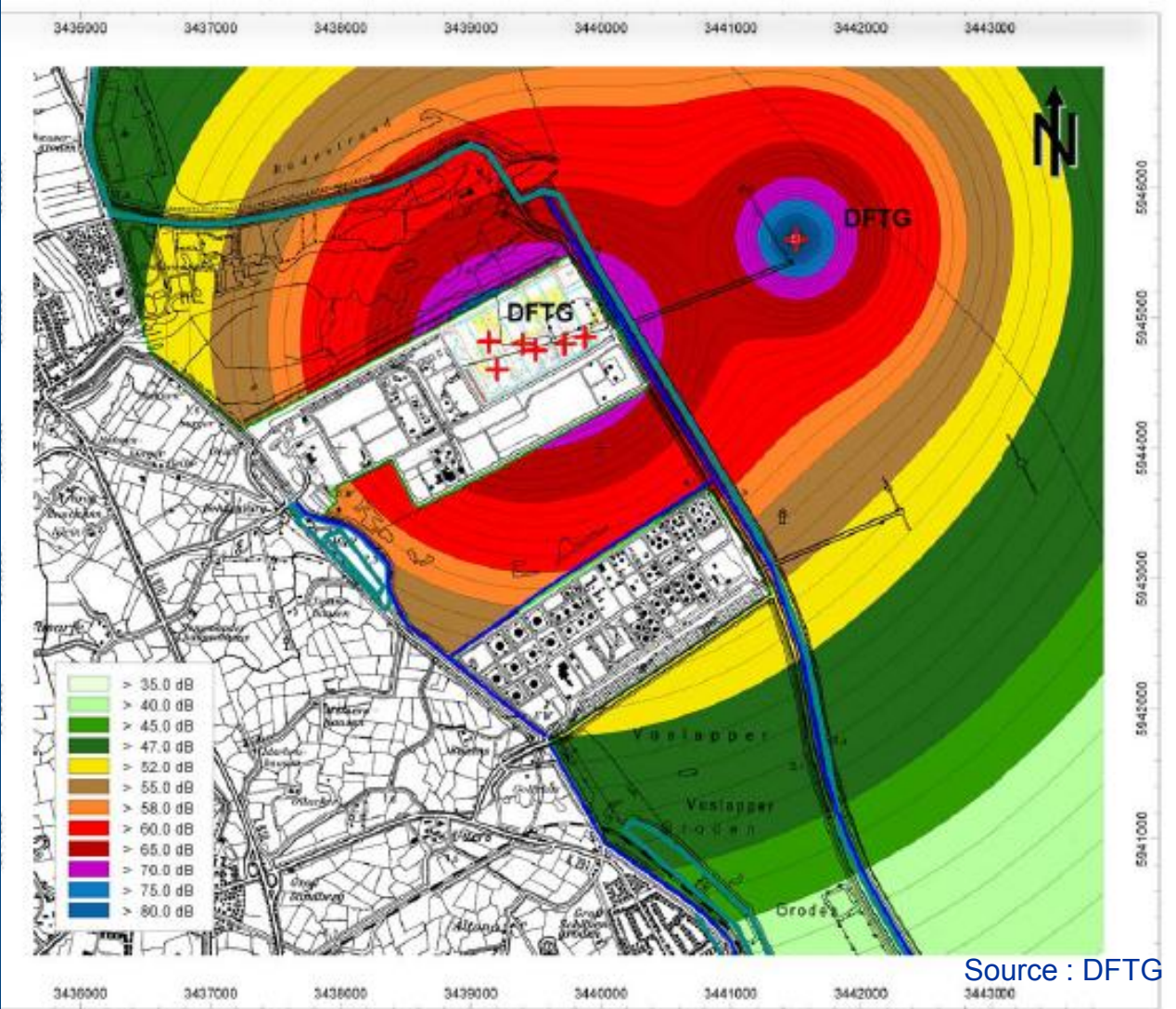

- Introduction
- Key Factors for Site Selection
- Environmental Requirements
- Case Study
- Consequences for *LNG* Terminals
- What to do?
- Summary



■ During design phase

- Detailed Assessments required
- Layouts to be subject of changes
- Noise protection required
- Less chance to modify during DE
- More engineering work
- Step away from “Standard” design

■ Long-winding and complex permit process

- Safety Report 422 pages
- Maritime Risk Study 175 pages
- Report § 29a expert 379 pages
- EIA (UVU, FFH, saP) 750+ pages
- Meetings with authorities > 40
- Protocol public hearing 110 pages

Source: DFTG

■ Construction schedule



Source: GATE LNG

- Work only during daytime
- Seasonal restriction
- Review Constructability methods
- Additional Method statements
- Extra monitoring
- Extra reporting

■ Operation

- Seasonal restriction
- Operational restriction
- Extra monitoring
- Extra reporting
- Incidental provisions for expansion

■ Cost effects

- In design phase
 - In construction phase
 - During operation
 - For expansion
- ▶ Significant portion of project costs

- Introduction
- Key Factors for Site Selection
- Environmental Requirements
- Case Study
- Consequences for *LNG* Terminals
- What to do?
- Summary



■ Location and Size of Terminal

- Alternative locations
 - Size of equipment
 - No. of equipment
 - Type of equipment
 - Expansion plan
- Assess
 - Review
 - Develop
 - Verify
 - Decide

▶ Selection of Environmentally-friendly Technology

■ Selection of Equipment

- Type of vaporization
- Energy source
- BOG – handling
- Energy consumption
- Construction methods
 - Ramp up method

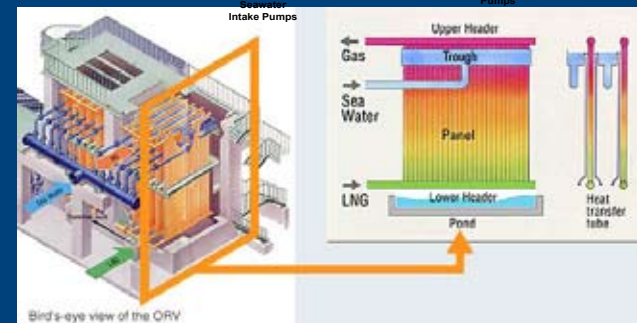
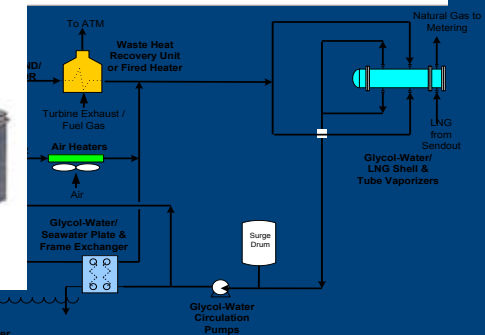
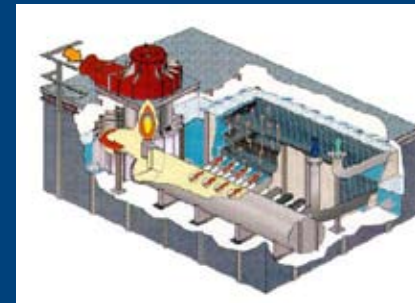
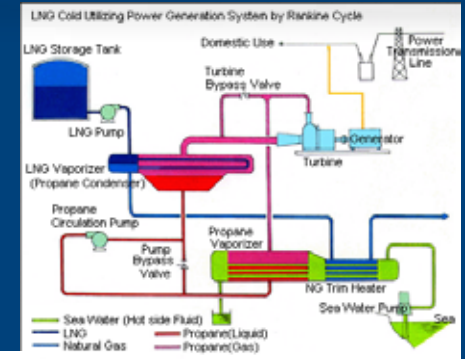

Source: Public Domain

■ Good Practice

- Dialog with Authorities
- Involve stakeholders from the beginning
- Raise awareness and commitment
- Take actions to stimulate innovation
 - “Clean Ship Innovations”
 - “Clean Terminal Innovations”
- Keep everyone involved

■ Good Practice

- Convert strategies into an action plan
- Communicate on your environmentally orientated strategy
- Promote your approach
- Develop your green image



- Introduction
- Key Factors for Site Selection
- Environmental Requirements
- Case Study
- Consequences for *LNG* Terminals
- What to do?
- Summary



- ▶ Environmental requirements can set considerable constraints on the technical requirements of an LNG Import terminal
- ▶ Environmental requirements can catch a considerable portion on the investment of an LNG Import terminal
- ▶ Technical solutions are available
- ▶ To combine with soft elements
- ▶ But do not expect one solution



THANK YOU FOR YOUR ATTENTION!



Contact Details

Hans –J. Grossmann

Managing Director

GOC Engineering GmbH

hans.grossmann@goce.de

www.goce.de